

Earth Continuity Monitor GCM-52

Installation guide

Installation guide

It is essential that the GCM Earth Continuity Monitor be installed in such a way that the generated signal must travel via the fully insulated *pilot conductor* direct to the *Remote Module*. The latter must be situated remotely from the GCM Monitor as shown in Fig.6 below. The main *earth conductor* **must** form the return path to the GCM Monitor via the equipment frame at each end and at intermediate points where applicable. The *pilot* and *earth* conductors plus the *remote module* thus comprise the monitored loop.

On completion of the installation and connection of the wiring harness to the pilot and earth conductors the following tests should be made before connection to the 110 volt ac supply to the monitor.

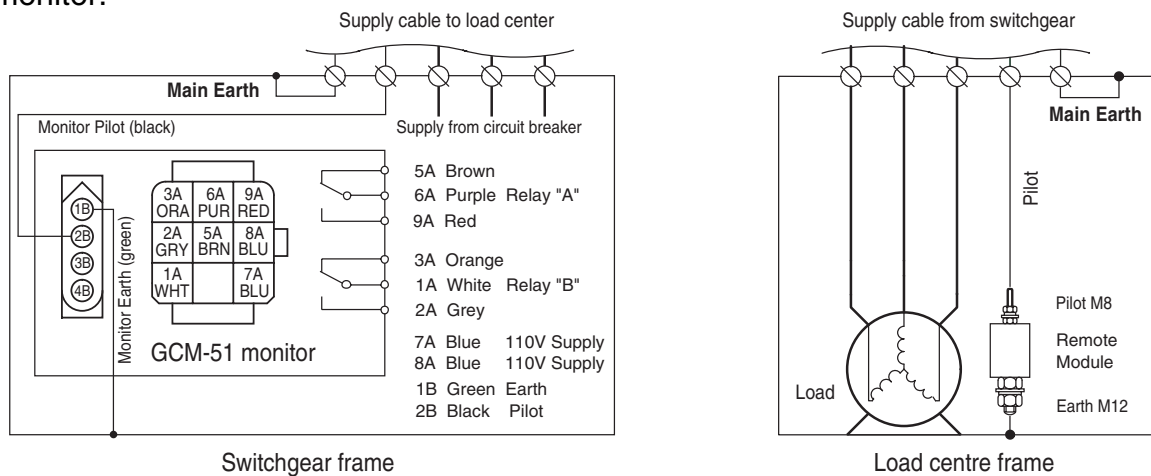
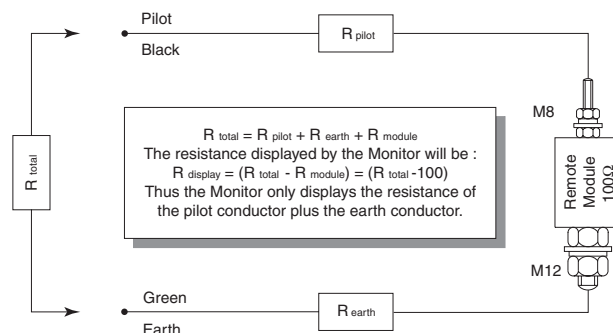

Fig 6
GCM-52 connection

Test schedule

1. With *remote module* disconnected check the insulation of the *pilot* and *earth* . Test should read infinity.
2. Connect the *remote module* with the M12 bolt fastened to the load centre frame (earth) and the *pilot conductor* connected to the M8 bolt.
3. Measure the total loop resistance between *pilot* and *earth*. This reading should be a minimum of 100Ω and a maximum of 150Ω.



Earth Continuity Monitor GCM-52

Installation guide

4. Plug the 9 pin and 4 pin plugs into their sockets at the rear of the GCM-52 Monitor or slide the chassis into the 1D case if a GCM-52-1D is being installed and switch on the 110v ac supply. The monitor will run a self test and calibration routine, then display the Loop/Trip readings. The startup display sequence is shown below:

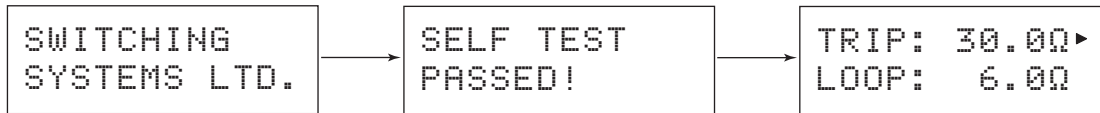

When the self test and calibration routine has run successfully and the trip and loop values are displayed the GCM-52 monitor is fully operational and ready for service. If the password and trip level have not been set this should be done now. Refer to page 6 of the User Manual for instructions.