

Capacitor Storage Unit

Model CSU-110



Preliminary

Contents

1. Introduction 3

2. Theory of operation 3

3. Specifications 4

4. Installation guide 5

5. Typical connection diagram 6

6. Mechanical outline 7

Introduction

Electrical reticulation systems always employ circuit breakers on the incoming supply so that in the event of a fault in the consumer's plant the supply can be quickly disconnected regardless of the high fault currents that may be present. Breakers used in MV Switchgear employ a shunt trip coil to trigger the breaker disconnect mechanism. In addition to the breakers the MV Switchgear will incorporate protection relays to detect fault conditions such as over current or short circuits. Modern electronic protection devices require auxilliary power in order to operate. If battery tripping is not used and power is supplied from the VT then when a fault occurs the supply voltage can drop to a level where the protective devices cannot operate and it is impossible to disconnect automatically.

To overcome this problem battery powered tripping units are used. However this approach introduced a maintenance problem where batteries had to be checked and replaced at regular intervals. Poor battery maintenance resulted in the protective devices becoming inoperative and as a result compromising system safety.

Switching Systems developed a Capacitor Storage Unit (CSU) to supply power for the breaker trip coil and electronic sensing relay(s). Capacitors are used for energy storage so no maintenance is required. The CSU provides a reliable cost effective solution to maintaining electrical system safety and may be used as a backup for battery powered trip units. It is an ideal solution for switchgear in remote locations where maintenance free operation is required.

Theory of operation

The Capacitor Storage Unit (CSU) employs capacitors to store the energy required to power the electronic protection relays and operate the circuit breaker shunt trip coil. The capacitors are charged from up to five separate sources

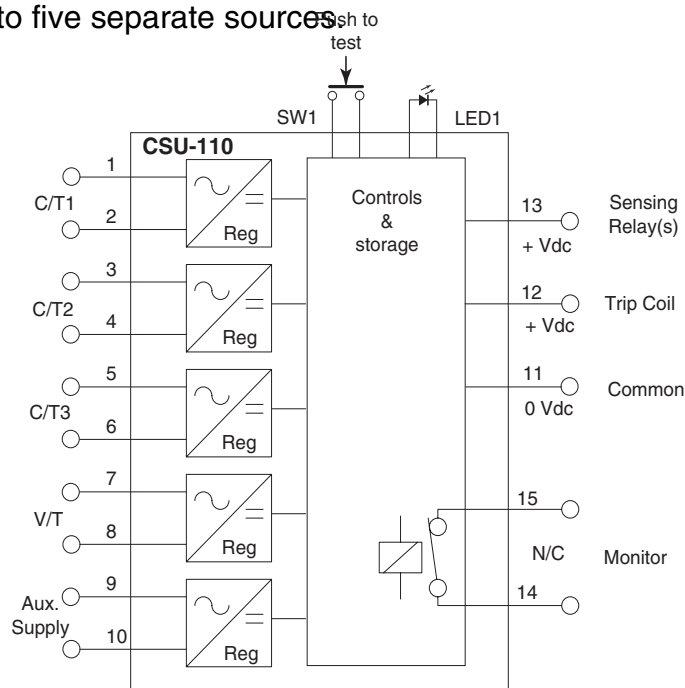

Fig 1
CSU Block diagram.

User Manual

Power is supplied from the three main current transformers on the incoming supply via interposing CT's on each phase. Any one of these inputs is capable of fully charging the capacitors with 15% load current flowing in the supply. In addition a voltage input is provided; this is supplied from a three phase voltage transformer (VT). An Auxillary supply input may be connected to 110. The provision of multiple supply inputs ensures the capacitors are always fully charged regardless of supply condition.

Two independent DC voltage outputs (110Vdc \pm 15%) are available to power the breaker trip coil and the electronic relay(s). A potential free relay contact is provided to monitor the charge state of the capacitors. This contact is open when the capacitors are charged and closed when the capacitor voltage is too low to operate the protective devices.

A test button on the front panel may be used to test the CSU. Pressing and holding the test button discharges the capacitors; the LED indicator should go out after a minimum period of 25 seconds. Discharge times of 25 seconds confirm that the capacitors are healthy and were fully charged. Discharge times of less than 25 seconds indicate that the CSU is faulty and should be repaired / replaced.

Specifications

MODEL	CSU-110
INPUTS	
Current transformer CT1:	Interposing 10P10, 10VA ratio 5/1 or 1/1
Current transformer CT2:	Interposing 10P10, 10VA ratio 5/1 or 1/1
Current transformer CT3:	Interposing 10P10, 10VA ratio 5/1 or 1/1
Voltage transformer VT:	Primary – for supply, secondary 110VAC \pm 10%
Auxillary supply:	110VAC \pm 10%
OUTPUTS	
Sensing relay(s):	110Vdc \pm 15% maximum burden 10VA
Trip coil:	110Vdc \pm 15%
Monitor contact:	10A 250V potential free Open – Caps charged, unit OK Closed – Capacitor voltage too low.
INDICATOR	
Caps charged, unit OK:	Red LED
UNIT TEST	
Push button:	Push and hold to test; red LED must stay on min. 25sec.
TEMPERATURE	
Maximum ambient:	45°C
HOUSING	
ABS plastic enclosure:	262 x 135 x 83mm
CONNECTION	
Cable:	2.5mm ² copper panel wire
Screw terminal torque:	0.8 – 1.0Nm
LISTINGS & APPROVALS	None

Installation guide

The Capacitor Storage Unit is simple to install. Refer to the instructions below and to the typical connection diagram shown in Fig 2 on p6.

1. Mount the CSU-110 in the MV panel.
2. To ensure full protection connect *all* inputs.
3. If not already fitted install a VT and connect secondaries to VT input as shown in Fig 2 p6.
4. The Auxilliary Supply Input, terminals 9 & 10, should be connected to a 110VAC supply.
5. Install the interposing CT's: CT1, CT2 & CT3. These are connected in series with the protection CT's burden. The outputs should be connected to terminals 1 & 2, 3 & 4 and 5 & 6 respectively.
6. Connect the sensing relay(s) to terminal 13 (+110Vdc) & terminal 11 (0Vdc).
7. Connect the trip coil as shown in Fig 2 p6.
8. If remote monitoring of the CSU-110 is required connect monitoring circuit to terminals 14 & 15. The monitor contact is closed when there is no power or if the CSU is faulty. The contact is open when the CSU is energised and functional.
9. Switch on the main supply. The red LED should illuminate and the monitor relay contact (14&15) should be open.
10. To check the unit press and hold the test switch until the LED goes off. The red LED should remain on for a minimum time of 25 seconds after the switch was pressed.
11. When the above test is successful the CSU-110 is fully operational.

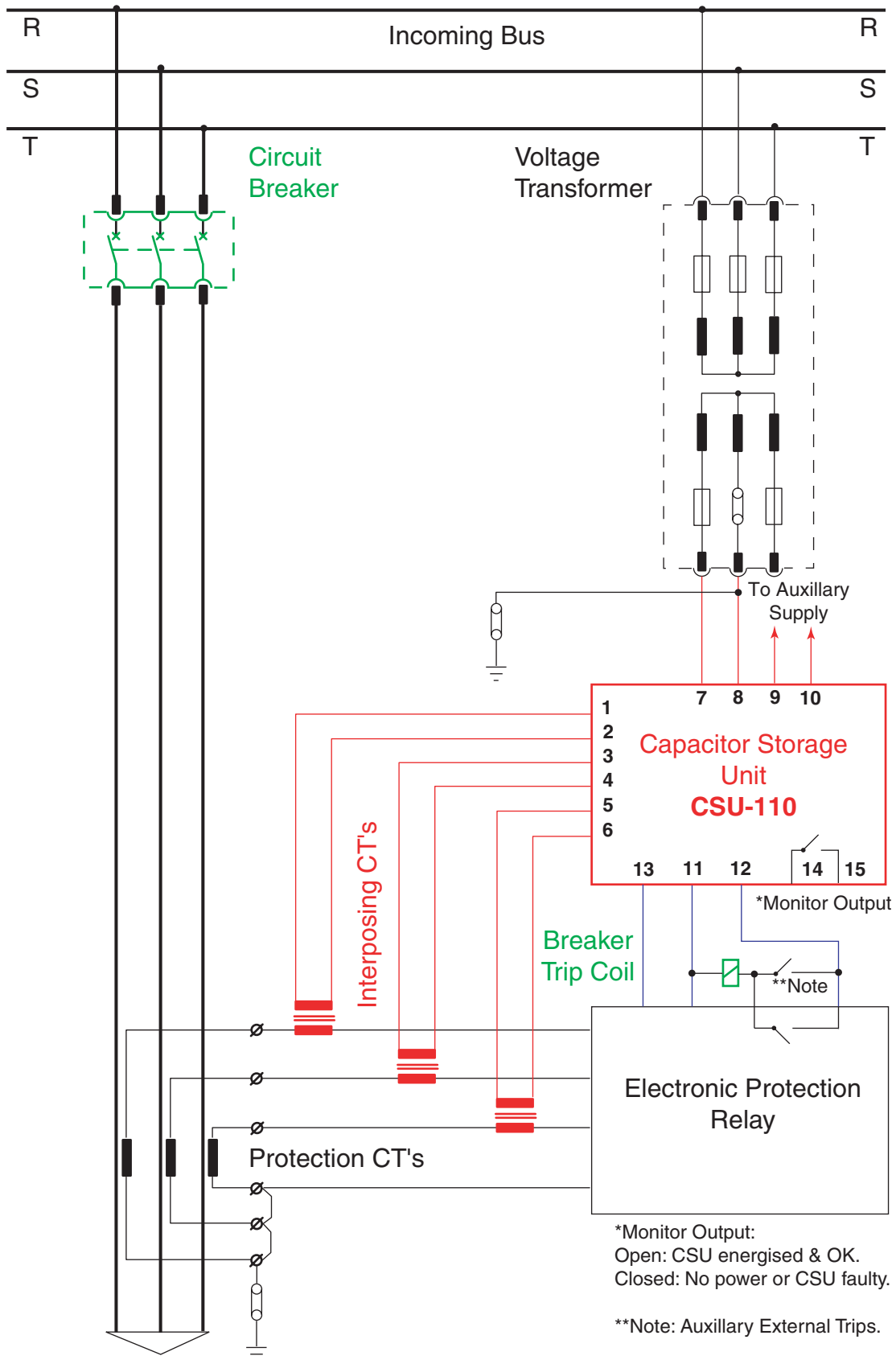

Fig 2
Typical connection diagram.

Mechanical outline

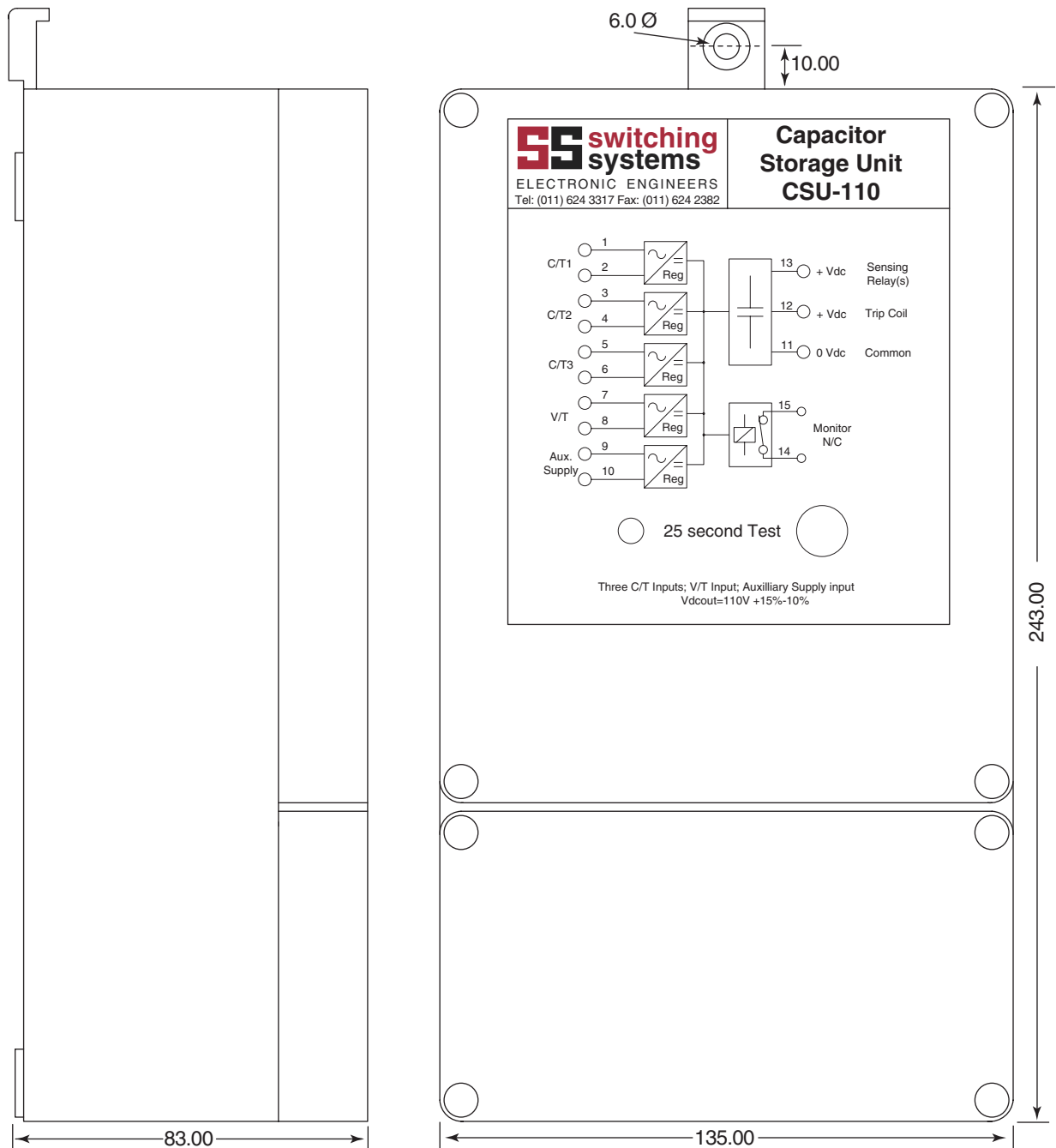

Fig 3
Dimensions of the CSU-110 in mm.

Capacitor Storage Unit

Model CSU-110

